

PART NR.

See dimensions table
"T" = Telemecanique
"W" = Weidmüller

COUNTRY OF ORIGIN

Germany

STANDARDS

REACH and RoHS compliant
DIN 46228/4

Compliant to EU directives 2002/96/EC (WEEE),
2002/95/EC (ROHS) AND 2003/11/CE

CORD END TERMINAL - CRIMPSTAR REEL

PHOTO / TECHNICAL DRAWING

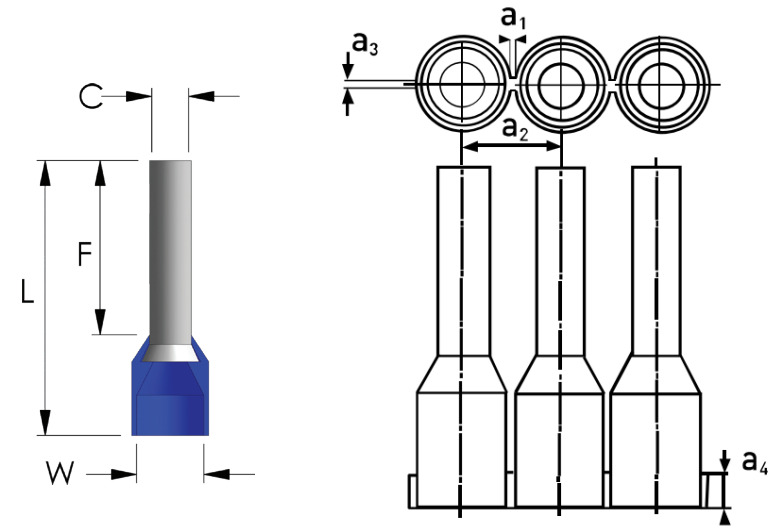
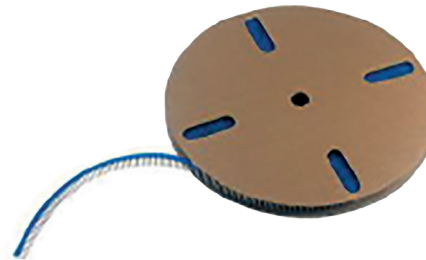

DIMENSIONS

Wire range	C	Part nr. "T"	UL	C	Part nr. "W"	UL	C	Part nr. DIN	UL	a1	a2	a3	a4	Pcs/reel
0,50 mm ² / 20 AWG		AHW 0.50N CSR	✓	Orange	AHO 0.50N CSR	✓		AHW 0.50N CSR	✓	0,2	3,6	0,25	1,5	4000
0,75 mm ² / 19 AWG	Blue	AHB 0.75N CSR	✓		AHW 0.75N CSR	✓	Grey	AHGRS 0.75N CSR	✓	0,2	3,6	0,25	1,5	4000
1,00 mm ² / 18 AWG	Red	AHR 1.00N CSR	✓	Yellow	AHG 1.00N CSR	✓	Red	AHR 1.00N CSR	✓	0,2	4,2	0,25	1,5	3500
1,50 mm ² / 16 AWG	Black	AHZ 1.50N CSR	✓	Red	AHR 1.50N CSR	✓	Black	AHZ 1.50N CSR	✓	0,2	4,2	0,25	1,5	3000
2,50 mm ² / 14 AWG	Grey	AHGRS 2.50N CSR	✓	Blue	AHB 2.50N CSR	✓	Blue	AHB 2.50N CSR	✓	0,2	5,0	0,25	1,5	2500

TECHNICAL SPECIFICATIONS

Terminal:

Red copper (Cu-ETP),
electro tin plated

Insulation:

Polypropylene (PP)

Min. coating thickness:

3 µm

Max. temperature:

105 °C

Reel:

Outer Ø 320 mm, core Ø 23 mm